

elumen8

CYC100 RGBW 100W COB Cyclorama Wash MKII

User Manual



Order codes: ELUM123

WARNING

FOR YOUR OWN SAFETY, PLEASE READ THIS USER MANUAL CAREFULLY BEFORE YOUR INITIAL START-UP!

- Before your initial start-up, please make sure that there is no damage caused during transportation.
- Should there be any damage, consult your dealer and do not use the equipment.
- To maintain the equipment in good working condition and to ensure safe operation, it is necessary for the user to follow the safety instructions and warning notes written in this manual.
- Please note that damages caused by user modifications to this equipment are not subject to warranty.



IMPORTANT:

The manufacturer will not accept liability for any resulting damages caused by the non-observance of this manual or any unauthorised modification to the equipment.

- Never let the power cable come into contact with other cables. Handle the power cable and all mains voltage connections with particular caution!
- Never remove warning or informative labels from the unit.
- Do not open the equipment and do not modify the unit.
- Do not connect this equipment to a dimmer pack.
- Do not switch the equipment on and off in short intervals, as this will reduce the system's life.
- Only use the equipment indoors.
- Do not expose to flammable sources, liquids or gases.
- Always disconnect the power from the mains when equipment is not in use or before cleaning! Only handle the power-cable by the plug. Never pull out the plug by pulling the power-cable.
- Make sure that the available mains supply voltage is between 100~240V AC, 50/60Hz.
- Make sure that the power cable is never crimped or damaged. Check the equipment and the power cable periodically.
- If the equipment has been exposed to drastic temperature fluctuation (e.g. after transportation), do not connect power or switch it on immediately. The arising condensation might damage the equipment. Leave the equipment switched off until it has reached room temperature.
- Never touch the fixture during operation as it may be hot.
- If the equipment is dropped or damaged, disconnect the mains power supply immediately and have a qualified engineer inspect the equipment before operating again.
- If your product fails to function correctly, stop use immediately. Pack the unit securely (preferably in the original packing material), and return it to your Pro Light dealer for service.
- Only use fuses of same type and rating.
- Repairs, servicing and power connection must only be carried out by a qualified technician. THIS UNIT CONTAINS NO USER SERVICEABLE PARTS.
- This lighting fixture is for professional use only - it is not designed for or suitable for household use. The product must be installed by a qualified technician in accordance with local territory regulations. The safety of the installation is the responsibility of the installer. The fixture presents risks of severe injury or death due to fire hazards, electric shock and falls.
- Warning! Risk Group 2 LED product according to EN 62471. Do not view the light output with optical instruments or any device that may concentrate the beam.
- WARRANTY: Two years from date of purchase.

OPERATING DETERMINATIONS

If this equipment is operated in any other way, than those described in this manual, the product may suffer damage and the warranty becomes void. Incorrect operation may lead to danger e.g: short-circuit, burns and electric shocks etc.

Do not endanger your own safety and the safety of others!

Incorrect installation or use can cause serious damage to people and/or property.

CYC100 RGBW 100W COB Cyclorama Wash MKII

The CYC100 from eLumen8 is a compact, quad colour cyclorama wash light suitable for theatre, stage or studio. The wide angle, 90° x 105° beam is designed to deliver rich, even tones across large areas while the COB LED technology ensures a perfect colour mix without any multi coloured shadows.

- 100W quad-colour COB LED (RGBW (White LED is 6500K))
- Beam angle: 90° x 105°
- 687 Lux @ 2m (full on)
- 1.2kHz refresh rate
- DMX channels: 4/7/12 selectable
- Stand alone operation including manual RGBW colour mix, 64 preset colour macros and 9 programs
- 0 - 100% 16 bit dimming and variable strobe
- 4 dimming curves with two dimming response times: Linear, square law, inverse square law and S-curve
- Bracket allows for multiple rigging or floor standing applications
- 4 push button menu with OLED display
- PowerCON input/output
- 5-Pin XLR input/output
- Eight leaf barn doors with integral gel frame
- Temperature controlled fan



Specifications	CYC100 RGBW
Power consumption	105W
Fuse	T2A 250V
Power supply	100~240V, 50/60Hz
Dimensions	336 x 270 x 281mm
Weight	4.3kg
Order code	ELUM123

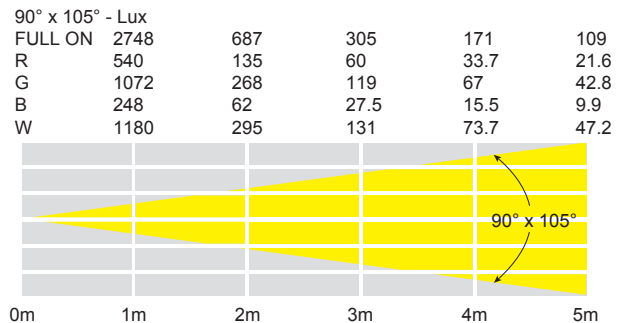

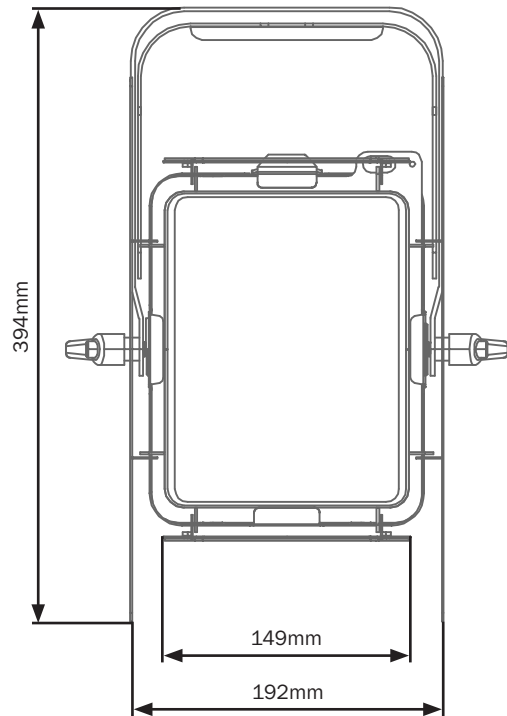
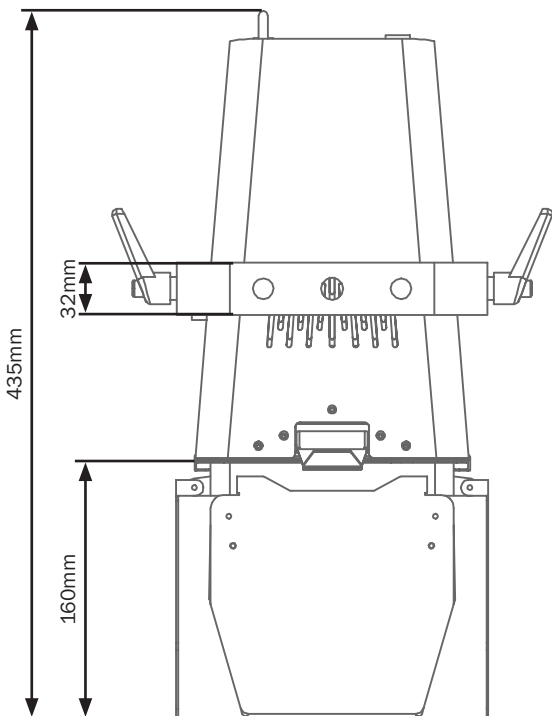
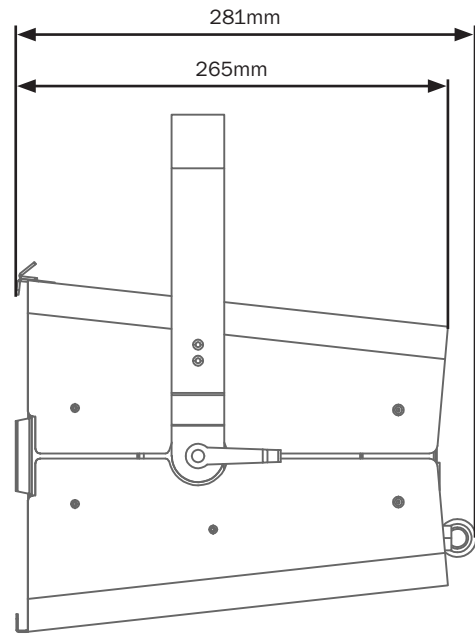
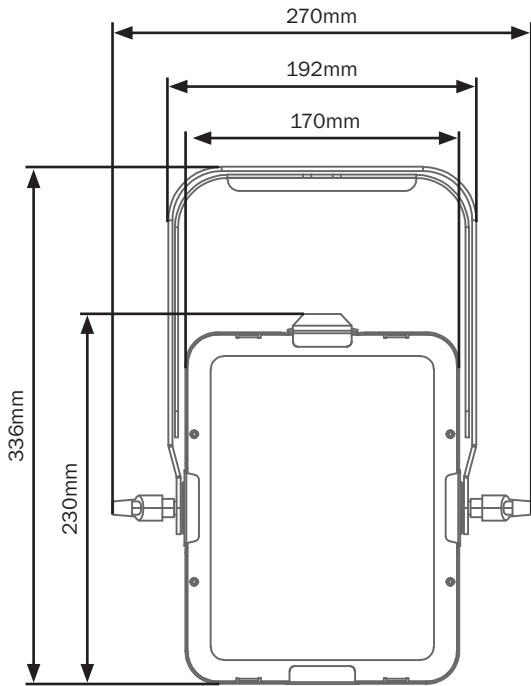

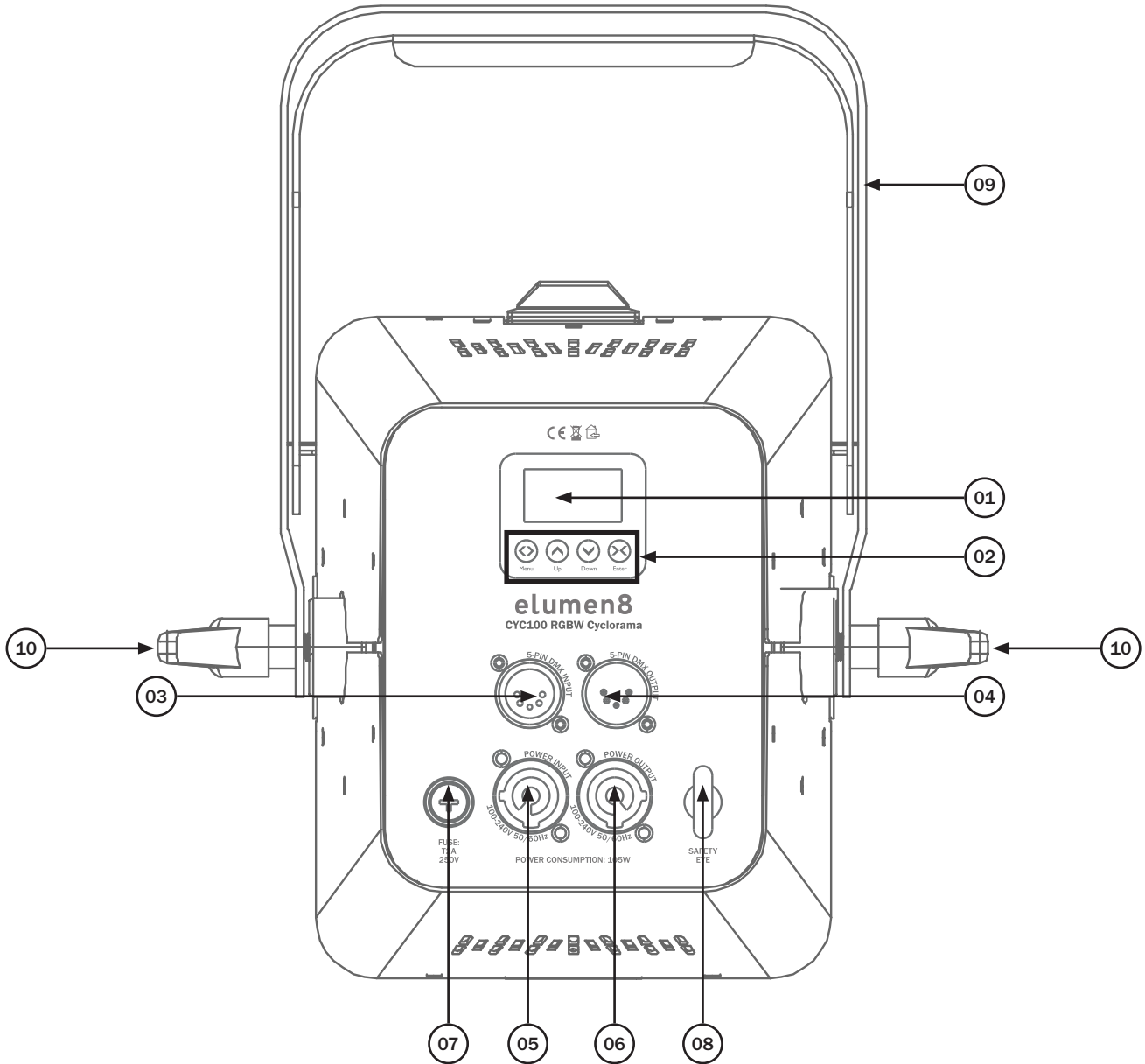

- 01 - OLED display
- 02 - Function buttons
- 03 - 5-Pin DMX input
- 04 - 5-Pin DMX output

- 05 - PowerCON input
- 06 - PowerCON output
- 07 - Fuse T2A 250V
- 08 - Safety eye

- 09 - Hanging bracket
- 10 - Hanging bracket adjustment knobs

In the box: **1 x fixture,**
1 x barn door,
1 x power cable
& 1 x user manual

Before installing the fixture, the supporting structure (ie. truss) must be able to hold a minimum of 10 times the fixtures weight without any deformation (eg. 15kg - 150kg point load). The fixture must be secured with a secondary safety attachment when being installed (ie. an appropriate safety cable). Never stand directly below the fixture when mounting, removing, and/or servicing.

Overhead installation requires experience and qualifications to calculate working load limits, the material being used at the installation area and periodic safety inspections of the fixture and installation material. If you do not have the relevant experience and/or qualifications please do not attempt the installation yourself. The installation should be checked annually by a qualified person.

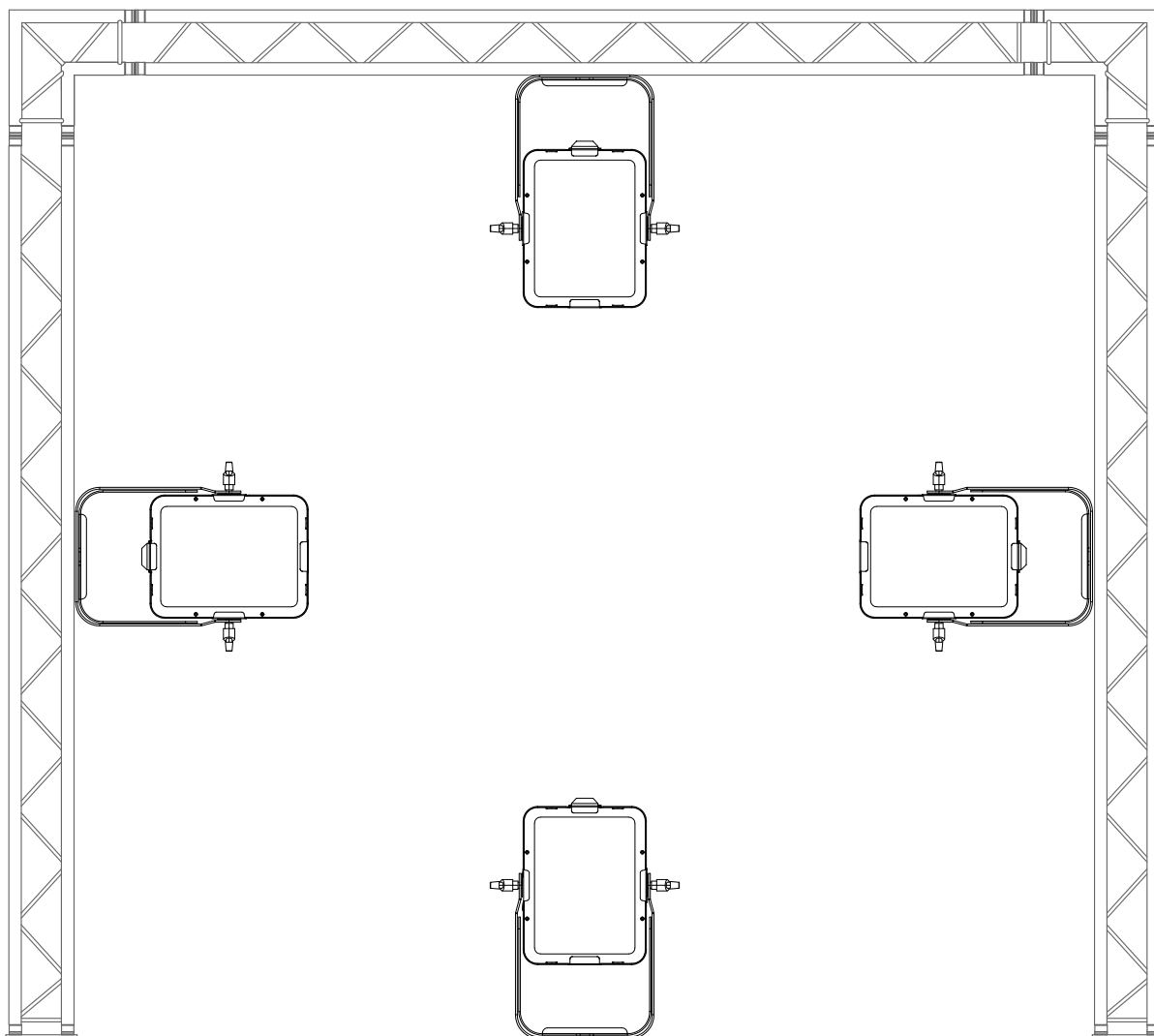

The eLumen8 CYC100 RGBW 100W COB Cyclorama Wash MKII can be operated in a number of mounting positions as shown in the diagram above, hanging upside-down from the ceiling or truss, mounting sideways on truss or stood upright on a flat level surface. Always use a safety wire as an extra safety precaution to prevent damage/injury in the event a clamp fails (see the next page for clamp installation). Never use the carry handles for secondary attachments.

Control Panel Menu:

The OLED control panel situated on the front of the fixture allows the user to access the menu system to adjust the fixtures settings.

When the unit has been powered on the display will show “**CYC100 RGBW Cyclorama**”.

The fixture will then return to its home screen.

Pressing the “**MENU**” button once will take the user to the fixtures main menu. Using the “**UP**” and “**DOWN**” buttons you can then navigate between the different options in the main menu. Pressing the “**ENTER**” button on one of these options allows you to access the sub menu where you can use the “**UP**” and “**DOWN**” buttons to select option/value required. Once the option/value has been selected press the “**ENTER**” button once more to confirm the setting.

To exit out of any of the above options, press and hold the “**MENU**” button.

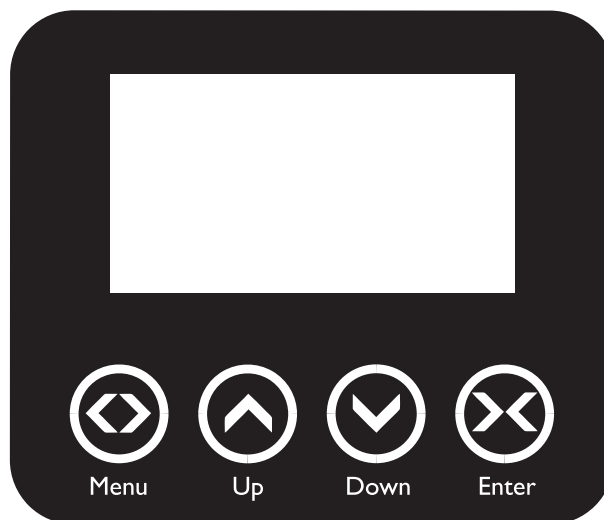

Main Menu	Sub Menu	Options/Values (Default Settings in BOLD)		Description
DMX Functions	DMX Address	001 -512		DMX Address Setting
	Mode	4 Channel		DMX Channel Setting
		7 Channel		
		12 Channel		
	DMX Fail	M/S (Master/Slave)		DMX Fail Setting
		Hold		
		Blackout		
	View DMX Value	1. Red		View DMX Value
		2. Green		
		3. Blue		
4. White				
...				
Manual Settings	Mode	Auto		Auto (Show)/
		Manu Defined		Manual Mode Setting
	Show Chase	Show 0	Co: 1-64	Static Colour Mode
		Show 1 - Show 9	Sp: 0-99	Auto (Show) Modes
Fixture Settings	Dimmer Curve	Linear		Dimming Curve Setting
		Square Law		
		Inv SQ Law		
		S Curve		
	Dimmer Speed	LED		Dimming Speed Setting
		Halogen		
	White Balance	Red		White Balance Setting
Green				
Blue				
Display Settings	Display Inverse	No		Display Inverse Setting
		Yes		
	Backlight Auto Off	No		Backlight Setting
Yes				
	Display Contrast	0-30 (15)		Display Brightness Setting
Fixture Test	Auto Test			Auto Test
	Manual Defined	1. Red	000-255	Manual Mode
		2. Green	000-255	
		3. Blue	000-255	
		4. White	000-255	
		5. Dimmer	000-255	
		6. Strobe	000-255	
Fixture Information	Fixture Hour	xxx		Fixture Run Time
	Firmware Version	CPU-A V x.x B x.x		Fixture Firmware Version
Special Functions	Factory Settings	No		Default Factory Settings
		Yes		

DMX channel modes:

Channel			Value	Function
4 Channel	7 Channel	12 Channel		
1	1	1	000-255	Red dimmer (0-100%)
2	2	2	000-255	Green dimmer (0-100%)
3	3	3	000-255	Blue dimmer (0-100%)
4	4	4	000-255	White dimmer (0-100%)
-	-	5	000	Not function
			001-004	Colour Macro 1
			005-008	Colour Macro 2
			009-012	Colour Macro 3
			013-016	Colour Macro 4
			017-020	Colour Macro 5
			021-024	Colour Macro 6
			025-028	Colour Macro 7
			029-032	Colour Macro 8
			033-036	Colour Macro 9
			037-040	Colour Macro 10
			041-044	Colour Macro 11
			045-048	Colour Macro 12
			049-052	Colour Macro 13
			053-056	Colour Macro 14
			057-060	Colour Macro 15
			061-064	Colour Macro 16
			065-068	Colour Macro 17
			069-072	Colour Macro 18
			073-076	Colour Macro 19
			077-080	Colour Macro 20
			081-084	Colour Macro 21
			085-088	Colour Macro 22
			089-092	Colour Macro 23
			093-096	Colour Macro 24
			097-100	Colour Macro 25
			101-104	Colour Macro 26
			105-108	Colour Macro 27
			109-112	Colour Macro 28
			113-116	Colour Macro 29
			117-120	Colour Macro 30
			121-124	Colour Macro 31
			125-128	Colour Macro 32
			129-132	Colour Macro 33
133-136	Colour Macro 34			

DMX channel modes:

Channel			Value	Function
4 Channel	7 Channel	12 Channel		
-	-	5 (cont.)	137-140	Colour Macro 35
			141-144	Colour Macro 36
			145-148	Colour Macro 37
			149-152	Colour Macro 38
			153-156	Colour Macro 39
			157-160	Colour Macro 40
			161-164	Colour Macro 41
			165-168	Colour Macro 42
			169-172	Colour Macro 43
			173-176	Colour Macro 44
			177-180	Colour Macro 45
			181-184	Colour Macro 46
			185-188	Colour Macro 47
			189-192	Colour Macro 48
			193-196	Colour Macro 49
			197-200	Colour Macro 50
			201-204	Colour Macro 51
			205-208	Colour Macro 52
			209-212	Colour Macro 53
			213-216	Colour Macro 54
			217-220	Colour Macro 55
			221-224	Colour Macro 56
			225-228	Colour Macro 57
			229-232	Colour Macro 58
233-236	Colour Macro 59			
237-240	Colour Macro 60			
241-244	Colour Macro 61			
245-248	Colour Macro 62			
249-252	Colour Macro 63			
253-255	Colour Macro 64			
-	5	6	000-255	Colour Temperature (2800K-7200K)
-	6	7	000-255	Master dimmer (0-100%)
-	-	8	000-255	Dimmer fine (0-100%)

DMX channel modes:

Channel			Value	Function
4 Channel	7 Channel	12 Channel		
-	-	9	000-049	Dimming Curve selected via the fixture
			050-099	Linear
			100-149	Square Law
			150-199	Inv SQ Law
			200-255	S Curve
-	7	10	000-049	LED off
			050-099	LED on
			100-149	Strobe (slow-fast)
			150-199	LED on
			200-249	Random Strobe (slow-fast)
-	-	11	000-002	No function
			003-030	Show 1
			031-058	Show 2
			059-086	Show 3
			087-114	Show 4
			115-142	Show 5
			143-170	Show 6
			171-198	Show 7
			199-226	Show 8
			227-255	Show 9
-	-	12	000-255	Show speed (slow-fast)

Please note: the Show modes will not function without the dimmer channel being greater than 0.

When using Master/Slave mode via the show modes the slave should be set to Show 0.

Setting the DMX address:

The DMX mode enables the use of a universal DMX controller. Each fixture requires a “start address” from 1- 512. A fixture requiring one or more channels for control begins to read the data on the channel indicated by the start address. For example, a fixture that occupies or uses 7 channels of DMX and was addressed to start on DMX channel 100, would read data from channels: 100, 101, 102, 103, 104, 105 and 106. Choose a start address so that the channels used do not overlap. E.g. the next unit in the chain starts at 107.

DMX 512:

DMX (Digital Multiplex) is a universal protocol used as a form of communication between intelligent fixtures and controllers. A DMX controller sends DMX data instructions from the controller to the fixture. DMX data is sent as serial data that travels from fixture to fixture via the DATA “IN” and DATA “OUT” XLR terminals located on all DMX fixtures (most controllers only have a data “out” terminal).

DMX linking:

DMX is a language allowing all makes and models of different manufactures to be linked together and operate from a single controller, as long as all fixtures and the controller are DMX compliant. To ensure proper DMX data transmission, when using several DMX fixtures try to use the shortest cable path possible. The order in which fixtures are connected in a DMX line does not influence the DMX addressing. For example; a fixture assigned to a DMX address of 1 may be placed anywhere in a DMX line, at the beginning, at the end, or anywhere in the middle. When a fixture is assigned a DMX address of 1, the DMX controller knows to send DATA assigned to address 1 to that unit, no matter where it is located in the DMX chain.

DATA cable (DMX cable) requirements (for DMX operation):

This fixture can be controlled via DMX-512 protocol. The DMX address is set on the back of the unit. Your unit requires either a standard 3-pin or 5-pin XLR connector for data input/output, see images below.

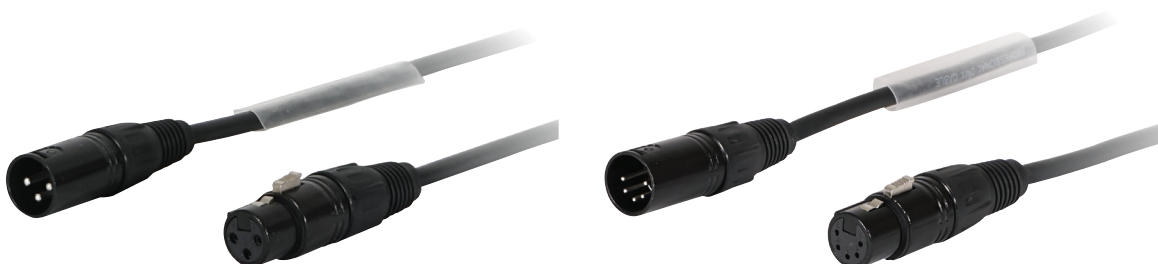

Further DMX cables can be purchased from all good sound and lighting suppliers or Prolight Concepts dealers.

Please quote:	3-Pin:	CABL10 – 2m	CABL11 – 5m	CABL12 – 10m
	5-Pin:	CABL185 – 2m	CABL187 – 5m	CABL188 – 10m

Also remember that DMX cable must be daisy chained and cannot be split.

Notice:

Be sure to follow the diagrams below when making your own cables. Do not connect the cables shield conductor to the ground lug or allow the shield conductor to come in contact with the XLRs outer casing. Grounding the shield could cause a short circuit and erratic behaviour.

Pin Configuration	
3-Pin	5-Pin
	Pin 1 - Ground
	Pin 2 - Negative
	Pin 3 - Positive
-	Pin 4 - N/C
-	Pin 5 - N/C

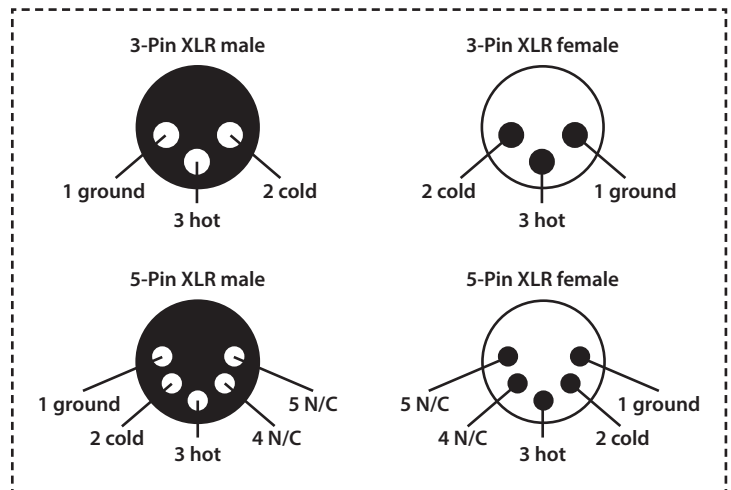
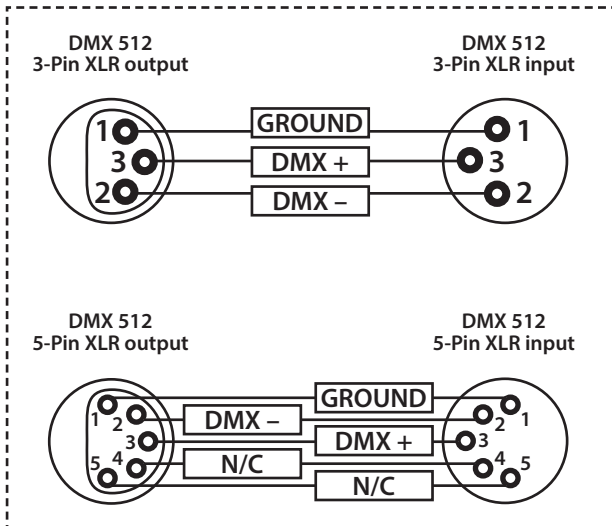

Line termination:

When longer runs of cable are used, you may need to use a terminator on the last unit to avoid erratic behaviour.

Using a cable terminator will decrease the possibilities of erratic behaviour.

(3-pin - Order ref: CABL90,
5-pin - Order ref: CABL89)

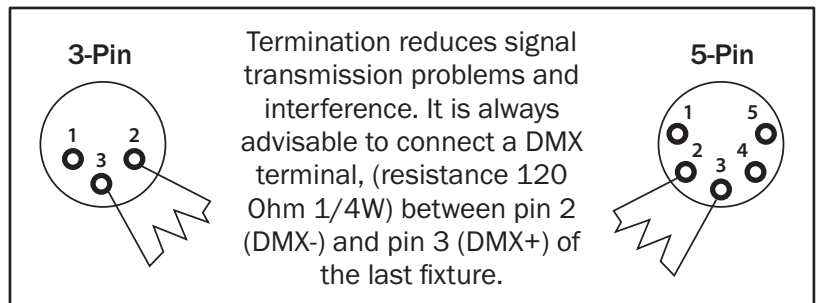

5-pin XLR DMX connectors:

Some manufactures use 5-pin XLR connectors for data transmission in place of 3-pin. 5-pin XLR fixtures may be implemented in a 3-pin XLR DMX line. When inserting standard 5-pin XLR connectors in to a 3-pin line a cable adaptor must be used. The diagram below details the correct cable conversion.

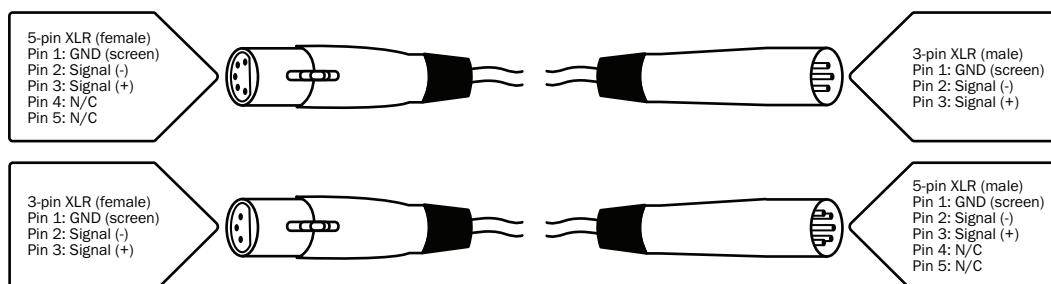

Power linking:

This fixture provides power linking via the power output on the rear allowing multiple units to be connected together. The maximum number of fixtures that can be connected is 16 fixtures @ 240V or 8 fixtures @ 120V (including the first fixture). After the maximum number of fixtures are connected a new power run will need to be started.

Please note: Caution should be used when power linking other fixtures to the CYC100 RGBW 100W COB Cyclorama Wash MKII as the power consumption of other fixtures will vary. Fixtures fitted with lamps often require 2/3 times more current on startup, these may require their own power source.

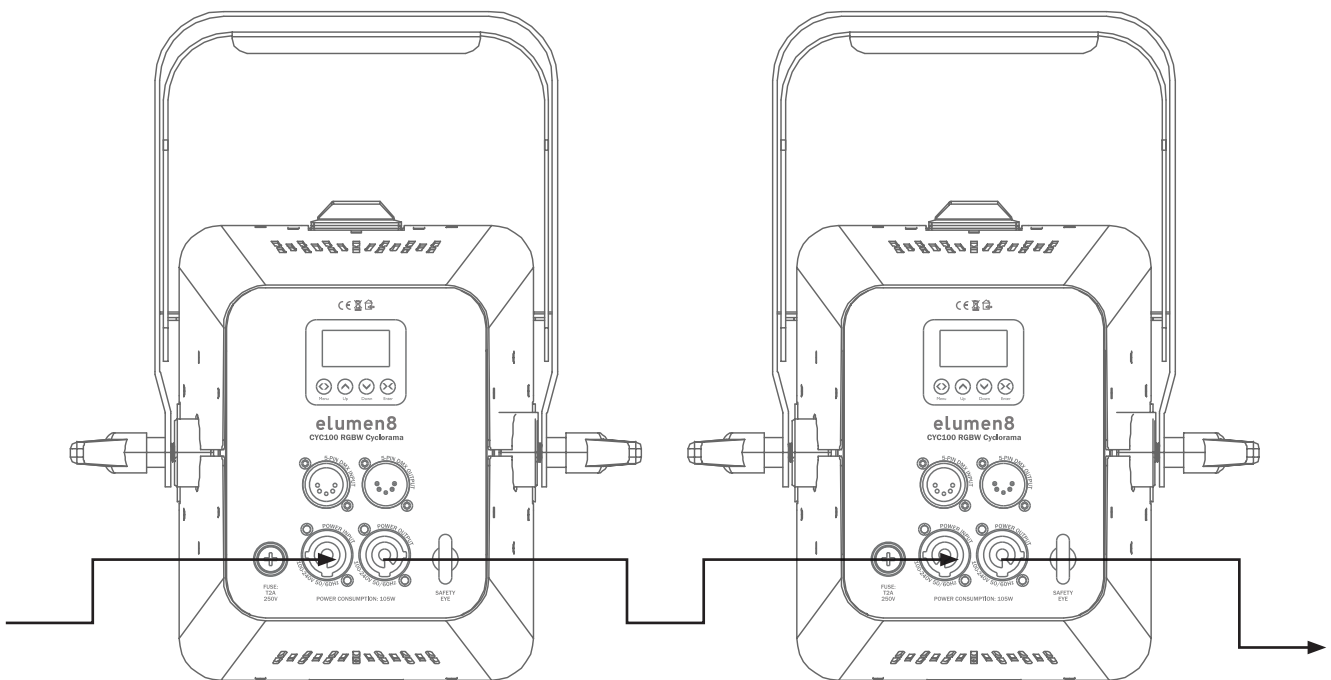



***Correct Disposal of this Product
(Waste Electrical & Electronic Equipment)***

(Applicable in the European Union and other European countries with separate collection systems)

This marking shown on the product or its literature, indicates that it should not be disposed with other household wastes at the end of its working life. To prevent possible harm to the environment or human health from uncontrolled waste disposal, please separate this from other types of wastes and recycle it responsibly to promote the sustainable reuse of material resources.

Household users should contact either the retailer where they purchased this product, or their local government office, for details of where and how they can take this item for environmentally safe recycling.

Business users should contact their supplier and check the terms and conditions of the purchase contract. This product should not be mixed with other commercial wastes for disposal.

